



ALCOCHEM
HYGIENE



Product catalogue

Professional insect light traps



Alcochem Hygiene Product Catalogue

Alcochem Hygiene - The Netherlands



2

Alcochem was founded in 1974. Alcochem Hygiene started in mid 2005 to produce a range of professional non-chemical pest control products for the global market. The HQ is located in Nijkerk (Netherlands) and there are established sales offices in the Waalre (NL), Beijing (CH) and Alicante (ES).

Alcochem currently operates in over 85 countries worldwide.

MANUFACTURING

Development, innovation, production and logistics are key disciplines of Alcochem's competences and has allowed the company to serve various industries. Operating around the globe, Alcochem has built up an extensive network, that offers innovative and / or high quality products to the market.

ALCOCHEM PRODUCT SERVICE COMMITMENT

Alcochem offers highly effective and durable products to their clientele. To live up to this, Alcochem's full range of insect control units comes with a 2 year warranty on electrical & mechanical defaults.

HOME / PROFESSIONAL

P5

Model	Lamp wattage (W)	Application Area (m ²)	CE /UKCA Approved	IP Rating	Weight (kg)	Dimensions (mm)
Armadilha 15R	1x 9 PL	15	Yes	21	1	ø 140 x 280
i-trap 30E	1x 15 SP / A	30 - 50	Yes	20	2	700 x 180 x 150
i-trap 50B	2x 15 SP / A	50 - 80	Yes	20	4	470 x 325 x 100

SP = Shatterproof • A = ASTRON • PL = PHILIPS

P6

INDUSTRIAL / HEAVY DUTY

Model	Lamp wattage (W)	Application Area (m ²)	CE /UKCA Approved	IP Rating	Weight (kg)	Dimensions (mm)
i-trap 125E	4x 15 SP / A	125 - 150	Yes	20	6	500 x 360 x 170

SP = Shatterproof • A = ASTRON

LED

P7-P8

Model	Lamp wattage (W)	Application Area (m ²)	CE /UKCA Approved	IP Rating	Weight (kg)	Dimensions (mm)
i-trap 30 LED	1x 9 ASTRON LED ⁽²⁾	30 - 50	Yes	20	2	494 x 147 x 165
i-trap 50 LED	2x 9 ASTRON LED ⁽²⁾	50 - 80	Yes	20	4	470 x 325 x 100
i-trap 125 LED	4x 9 ASTRON LED ⁽²⁾	125 - 150	Yes	20/65	6	500 x 360 x 170

OMNIVEO FLUORESCENT / LED / SMART

P9

Model	Lamp wattage (W)	Application Area (m ²)	CE /UKCA Approved	IP Rating	Weight (kg)	Dimensions (mm)
Omniveo ² /2WP / 2LED	2x 15 SP / A / LED ²	50 - 80	Yes	21/X5	4	520 x 365 x 150
Omniveo ³ /3WP / 3LED	3x 15 SP / A / LED ²	80 - 120	Yes	21/X5	5	520 x 365 x 150
 Omniveo ^{25C} /35C / LED	2 or 3x 15 SP / A / LED ²	50 - 80 / 80 - 120	Yes	21/X5	4 or 5	520 x 365 x 150

SP = Shatterproof • A = ASTRON • LED = ASTRON LED 9 Watt

 OMNIVEO SMARTCONTROL

P10-P11

FLUORESCENT UV-A LAMPS & SHATTERPROOFING

P12

ASTRON LED LAMPS

P13

OPERATING THE LAMPS / LAMP COATING TECHNOLOGY

P14

GLUEBOARD TECHNOLOGY

P15

UV-A TESTER

P16



WE ARE
WATCHING
YOU

OMNIVEO smartcontrol
clever & flexible monitoring of flying insects



Lamp wattage	1 x 9 w UV-A PL
Applicable area	15 m ²
CE certification	YES
IP Rating	21
Mounting position	Wall / Free standing
Glueboard	YES



FLEXIBLE MOUNTING

Effective coverage of areas up to 25 m²

Unit can be used in a wide variety of applications Glue board placed out of sight and is easy to replace from the top. Plastic housing offers durability.

Easy to service with direct access to lamp, board and starter. Meets ISO 9001 / RoHS / CE standard. Unit is HACCP compliant.

The heat entrapment design ensures that insects fly in faster. High powered effective UV-A lamp.

For use in homes, offices, shops and restaurants.

Armadilha 15R



Lamp wattage	1 x 15 W ASTRON UV-A shatterproof
Applicable area	30 - 50 m ²
CE certification	YES
IP Rating	20
Mounting position	Wall
Glueboard	YES



WALL MOUNTING

Effective & proven design

Energy saving UV-A lamp technology

1 year lifespan (9000 hrs) of the UV-A lamp

Environmental friendly:

RoHS / REACH / ISO and CB compliant

Fast and simple maintenance of the unit.

Optimized glueboard offers fast catch results and a fast analysis

High quality casing offers over 5 years of operational use

Fast mounting and fast service

For use in homes, offices, shops and restaurants.

i-trap 30E



30% improved performance over traditional units due to its unique attraction grid, which reflects the light onto the landing spot thereby stimulating the landing behaviour of flying insects.



Lamp wattage	2x 15 W ASTRON UV-A shatterproof
Applicable area	80 m ²
CE certification	YES
IP Rating	20
Mounting position	Wall
Glueboard	YES

WALL MOUNTING

Effective coverage of areas up to 80 m².

The unit can be mounted onto the wall.

The transparent front grid offers discretion and improved efficiency.

Glueboard discreetly placed behind the lamp.

High powered effective UV-A lamp.

Metal housing with durable ABS cover

Easy to service, direct access to lamp, board and starter.

Meets ISO 9001 / RoHS & the CE standard. HACCP compliant.

For use in shops and restaurants and dry industrial environments.

Executed with magnetic ballast + starter

2x 15 W ASTRON UV-A shatterproof

80 m²

YES

20

Wall

YES

i-trap 50B

Industrial / Heavy Duty

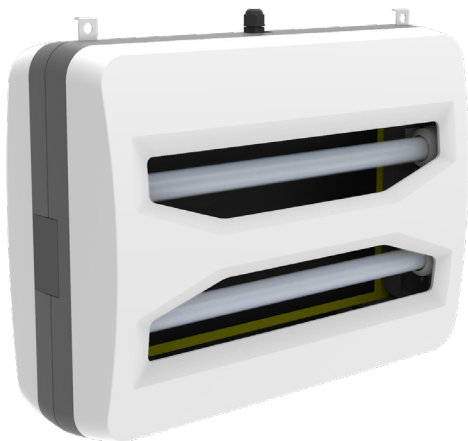

Lamp wattage	4x 15 W ASTRON UV-A shatterproof
Applicable area	125 - 150 m ²
CE/UKCA certification	YES
IP Rating	20 or 65
Mounting position	Ceiling
Glueboard	YES



CEILING MOUNTING

Effective coverage of areas up to 125 - 150 m²

Glueboard discreetly placed behind the lamp

Unit can be used in a wide variety of applications

2 years guarantee on mechanical & electrical performance

Meets ISO 9001 / RoHS & the relevant standard. HACCP compliant

Easy to service, direct access to lamps and glueboard

High powered effective UV-A lamps

4x 15 W ASTRON UV-A shatterproof

125 - 150 m²

YES

20 or 65

Ceiling

YES

i-trap 125E



ASTRON
LED
inside

LED technology offers clear advantages in terms of efficiency (lower energy consumption) and its footprint (compactness)

Lamp wattage
Applicable area
CE certification
IP Rating
Mounting position
Glueboard

220V
240V

50-60
Hz

CE

UK
CA

4x15
W

WALL MOUNTING

Effective coverage of areas up to 30 - 50 m².

Effective & proven design

Energy saving UV-A LED technology offers over 66 kW of savings per lamp per year.

An average lifespan of 3 years (25.000 hrs) with this LED lamp

Environmental friendly: no restricted chemicals used

RoHS / REACH / ISO and CB compliant

Fast and simple maintenance of the unit.

High quality casing offers over 5 years of operational use

For use in shops and restaurants and dry industrial environ-

1x 9 W ASTRON UV-A LED II

50 m²

YES

20

Wall

YES

i-trap 30 LED



ASTRON
LED
inside

LED technology offers clear advantages in terms of efficiency (lower energy consumption) and its footprint (compactness)

Lamp wattage
Applicable area
CE certification
IP Rating
Mounting position
Glueboard

110V
240V

50-60
Hz

CE

UK
CA

2x15
W

WALL MOUNTING

Effective coverage of areas up to 50 - 80 m².

The transparent front grid offers discretion and improved efficiency.

Glueboard placed discreetly behind the lamp, which offers optimised performance.

Energy saving UV-A LED technology offers over 66 kW of savings per lamp per year.

An average lifespan of 3 years (25.000 hrs) with this LED lamp

Environmental friendly: no restricted chemicals used

Easy to service, direct access to lamps and glueboard.

Meets ISO 9001 / RoHS & CE standard. HACCP compliant.

For use in shops and restaurants and dry industrial environ-

2x 9 W ASTRON UV-A LED II

50 - 80 m²

YES

20

Wall

YES

i-trap 50 LED

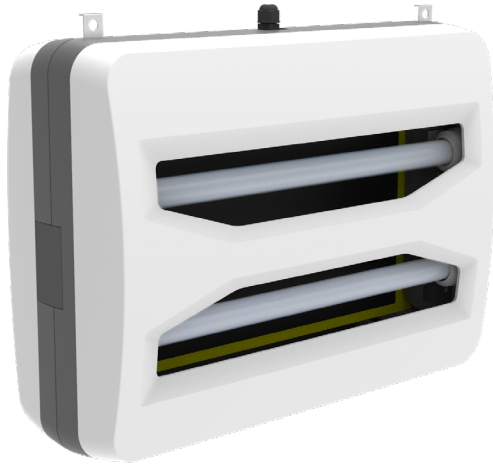

LED technology offers clear advantages in terms of efficiency (lower energy consumption) and its footprint (compactness)

Lamp wattage

Applicable area

CE/UKCA certification

IP Rating

Mounting position

Glueboard

CEILING MOUNTING

Effective coverage of areas up to 100 - 150 m².

The aluminium housing offers a light but strong body, easy to handle.

Glueboard placed discreetly behind the lamp, which offers optimised performance.

Energy saving UV-A LED technology offers over 66 kW of savings per lamp per year.

An average lifespan of 3 years (25.000 hrs) with this LED lamp

Environmental friendly: no restricted chemicals used

Meets ISO 9001 / RoHS & CE standard. HACCP compliant.

4x 9 W ASTRON UV-A LED II

125 - 150 m²

YES

20 or 65

Ceiling

YES

i-trap 125 LED





Fluorescent lamp



Lamp wattage	2x 15 W ASTRON UV-A shatterproof
Applicable area	50 - 100 m ² (2x 15 W) / 80 - 150 m ² (3x 15 W)
CE certification	CE / EMC / LVD / RoHS / REACH / ISO 9001 compliant
IP Rating	20 or 65
Mounting position	Wall
Glueboard	YES

WALL MOUNTING

Glueboard discreetly placed behind the lamp.
 Easy to service, direct access to lamps and glueboard.
 2 years guarantee on mechanical & electrical performance

For use in shops and restaurants and dry industrial environments.

OMNIVEO 2/3

LED - OMNIVEO² / OMNIVEO³ - 2 or 3 lamps



LED technology offers clear advantages in terms of efficiency (lower energy consumption) and its footprint (compactness)



Lamp wattage	2x 9 W ASTRON UV-A LED II / 3x 9 W ASTRON UV-A LED II (needs only 2x or 3x 9 Watt to offer the same UV-A output)
Applicable area	50 - 100 m ² (2 lamps) / 80 - 150 m ² (2 lamps)
CE certification	CE / EMC / LVD / RoHS / REACH / ISO 9001 compliant
IP Rating	20 or 65
Mounting position	Wall
Glueboard	YES

WALL MOUNTING

Effective coverage of areas up to 150 m² (3 lamps version)
 Glueboard discreetly placed behind the lamp.
 Energy saving UV-A LED technology offers over 66 kW of savings per lamp per year.

An average lifespan of 3 years (25.000 hrs) with this LED lamp
 Environmental friendly: no restricted chemicals used
 2 years guarantee on mechanical & electrical performance
 Easy to service, direct access to lamps and glueboard.

For use in shops and restaurants and dry industrial environments.

OMNIVEO 2/3 LED

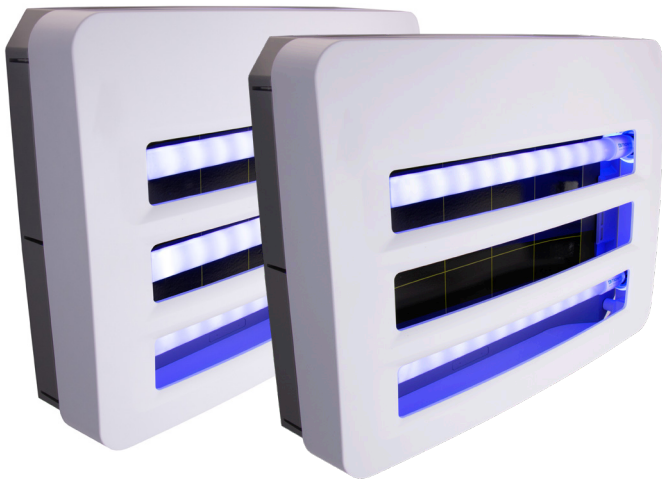

SMART counting technology with LED or Fluorescent lamps



LED



Lamp wattage

Applicable area

Certification

IP Rating

Mounting position

Glueboard

WALL MOUNTING

Camera module monitors over 80% of landing area
System communication via Bluetooth, LTE-M sim-chip with connection via KPN Netherlands

Back-up battery can store data up to over 1 year

Status of unit via built in multi color LED indicator

Data storage in protected area (Netherlands KPN), access via cloud software

optional - Communication with unit next to XG

optional - Philips electronic dimmable Eco Ballast

2 years guarantee on mechanical & electrical performance

2x 15 W or 3x 15 W ASTRON UV-A shatterproof or 2x 9 W or 3x 9 W ASTRON UV-A LED II

50 - 100 m² (2 lamps) / 80 - 150 m² (3 lamps)

CE / EMC / LVD / RoHS / REACH / ISO 9001 compliant

20 or 65

Wall

YES



INSECTS, CAUSING DISEASE AND INFECTIONS

Flying insects are a serious threat in the industry. These insects cause diseases, infections and decay.

And by consuming - or nesting in - stored products, these are no longer suited for consumption or production.

As a result the global industry suffers from losses, which go over 10 billions of Euro's. To assist the pest control market in their quest for better and faster information on the flying insect infestation level in any premises.

We developed an insect counting system, which can count insects and provide info on this in real time.

DATA

Periodically the data coming from the Smart Control units are collected and compiled on the server and the actual insect infestation level is calculated. Alarm levels can also be pre-programmed.

When this alarm level is reached, the info is relayed to a service technician, who can take immediate action and drive up to the

OMNIVEO 2/3 SC

THE SYSTEM

- FLEXIBELE SERVICE Offered when it is most needed. Control module is also executed with a bluetooth link up.
- FAST PROCESSING OF DATA
- HISTORICAL DATA IS RETAINED



Bluetooth communication with App.



Communication module for connection via the 2G network for the App and managementsystem.



- 2 or 3 tubes 15 Watt UV-A shatterproof / 2 or 3 LED ASTRON Tubes
- IP 20 or IP 65 (Suited for use in dry or wet areas)
- Reaching CE/ RoHS / REACH / ISO 9001 norm
- Recyclable parts

OMNIVEO SMART CONTROL

A CAMERA MODULE

Camera	High speed HR camera
Image capturing	In real time, up to 75 t/second
Board surveillance	≥ 60% of the board surface is monitored
Communication	Bluetooth to smartphone App (Android and iOS)
Traceability	Unique identifier (serial nr.) on module
Lifetime	Lifetime expectancy is 40.000 hrs

The camera monitors the insect activity in the insect light trap and registers all insects which land on the centrally placed glueboard. These data are registered by the processor and via the communication module these are periodically relayed to a cloud server.

CLOUD SERVER

This cloud server can be accessed by the user via any computer or smart phone. The cloud server provides access to a portal, developed by Alcochem Hygiene and her IT partner, where the incoming data can be processed and visualised in a flexible way.

A COMMUNICATION MODULE

Transmittance	Over the 2G network* + LTE-M (via sim card)
Antenne	Internal
Installment	Factory placed or retrofit (in the field)
Data collection	Via Cloud, API of Bluetooth
Data send	Amount of insects caught per time annum Alarm level (soft & hard) Lamp replacement status Failure mode unit
Traceability	Unique identifier (serial number) on module
Safety aspect	Data encrypted and protected

*If available in your country.

Once a connection with a smart phone is established, the smart control App will present full details on the technical status of the unit and present the insect trend analysis.

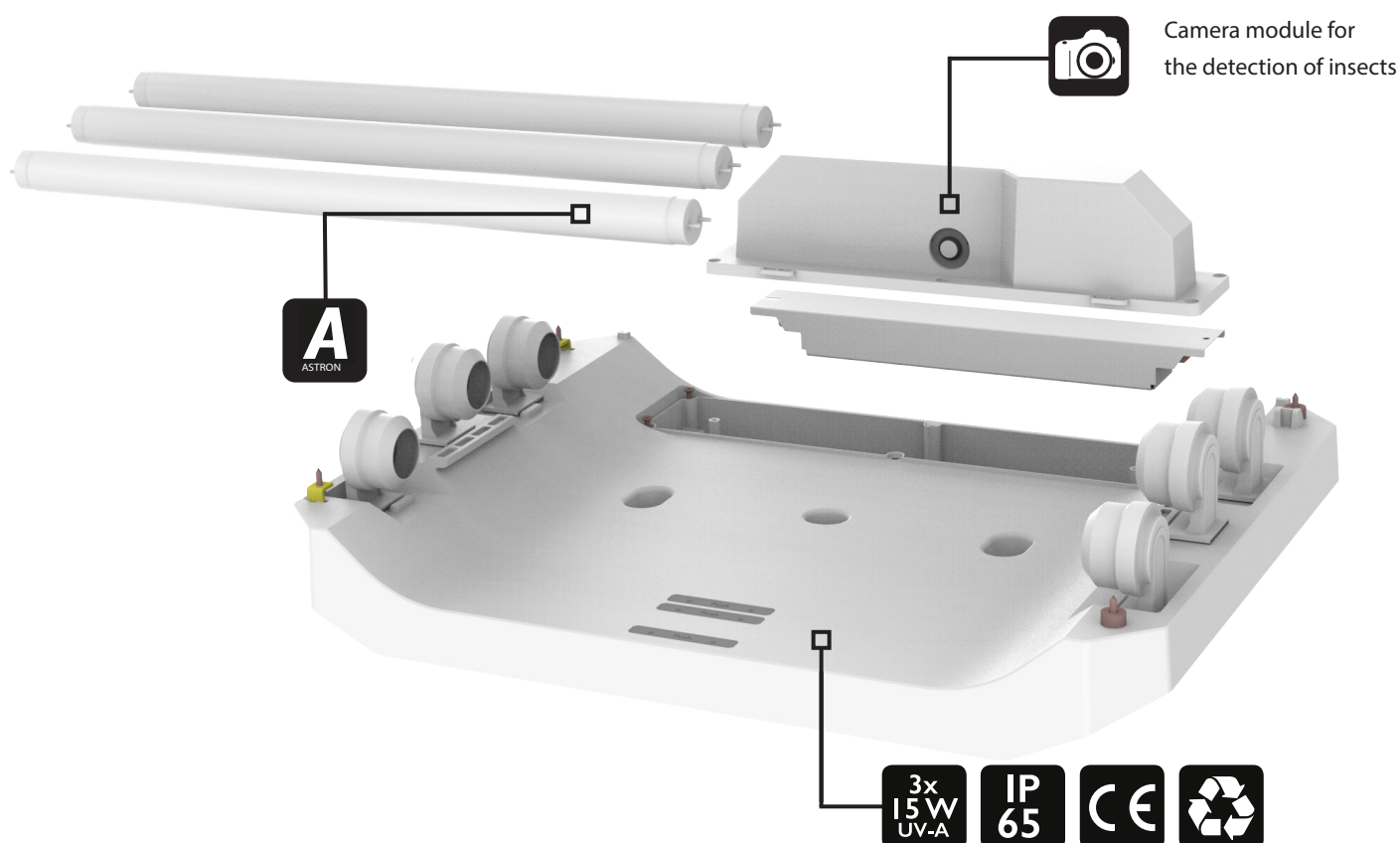

FLUORESCENT UV-A 15 WATT

In close partnership with Philips and ASTRON, Alcochem Hygiene has developed a full range of powerful UV-A lamps, used for insect trap applications. These lamps can be categorised in following lamp series:



A. The Long-life Philips UV-A lamps

These lamps are the Philips signature lamps and represent the very best available in the market

- A guaranteed 2 year life time
- A high UV-A output of around 80 % after 2 years of operational use
- The most "green" lamps available, due its extremely low use of mercury
- ISO 9001 production standard
- Manufactured in Europe
- Available in 15 Watt and 18 Watt UV-A straight lamp execution



B. The standard Philips UV-A lamps

These lamps are the standard Philips lamps and offer a reliable UV output

- A guaranteed 1 year life time
- A high UV-A output of around 60 % after 1 year of operational use
- Environmental friendly production, meets all environmental regulations
- ISO 9001 production standard
- Manufactured in Europe
- A wide range of various UV-A lamp executions are available



C. The ASTRON UV-A lamps

ASTRON is the Greek word for "Bright Star", which is exactly what these lamps offer. The ASTRON UV lamps are exclusively made for us and offer a reliable UV output

- A guaranteed 1 year life time
- A high UV-A output of around 60% after 1 year of operational use
- Environmental friendly production, meets all environmental regulations
- ISO 9001 production standard
- Manufactured in Europe
- And available for the best price, without compromising on quality & performance
- Available in 15 and 18 watt UV-A straight lamp or 18 & 36 Watt UV-A PL-L execution

All lamp series are available in a non-shatterproof and shatterproof execution.

The shatterproof coating used on all our UV-A lamps meet following specifications:

- A UV-A transmittance of minimum 95 % after 2 years of operational use.
- Drop test proof up to a drop height of 3 metres
- Genuine FEP coating, with a thickness of 0,3 mm
- Meet the EN 61549 Standard



A LED UV-A 9 WATT - ASTRON^{UV}

Recently special LED's have entered the market, which have the ability to generate ultraviolet light; UV-A LED's. These special LED's form the heart of a new generation UV-A lamps; the ASTRON UV LED II 9 Watt lamp. This new LED lamp replaces a Fluorescent 15 Watt lamp and for this it only needs 9 Watts to offer the same UV-A output performance.

Advantages ASTRON^{UV} LED II 9 Watt lamp

- The ASTRON UV LED II 9 Watt lamp is designed for low power consumption and high brightness.
- There are no harmful substances in the ASTRON UV LED II 9 Watt lamp. This is an eco-friendly product.
- The ASTRON UV LED II 9 Watt lamps complies to the int. standards and are perfectly safe to use.
- Specially designed single ultraviolet wavelength, optimised for insect control. The perfect replacement lamp for the 15 Watt mercury lamp.
- The ASTRON UV LED II 9 Watt lamp does not require a ballast and operates when connected directly to the mains^{*1}.
- The ASTRON UV LED II 9 Watt lamp only consumes 9 Watt and offers significant energy savings over the Fluorescent 15 Watt lamp. (see the table here below)
- The ASTRON UV LED II 9 Watt lamp has an operational lifetime of 25.000 hrs (3 years of constant use^{*2})
- The ASTRON UV LED II 9 Watt lamp uses class A LED's which comply to the highest standards. This ensures for a trouble free usage.
- The ASTRON UV LED II 9 Watt lamp is executed in a full shatterproof executed design (no glass is used)
- Guarantee period: 2 years, return to base

*1 (Spec: 100-240 V ~ 50-60 Hz)

*2 After 25.000 hours a loss in UV-A output is to be expected of 30 %

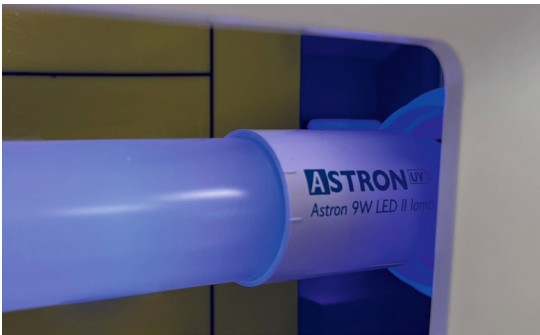

Technical specifications

No	Lamp and ballast combination	Typical energy consumption per hour (W)	Energy consumption per year (kW) (8760 hrs)	Energy saving of the ASTRON ^{UV} LED 15 Watt lamp (kW)
1	Fluorescent 15 Watt lamp and high frequency ballast	16.5	145	66
2	Fluorescent 15 Watt lamp and magnetic ballast	20	175	96
3	ASTRON ^{UV} LED 9 Watt lamp (with internal driver)	9	79	

OPERATING THE LAMPS - INTRODUCTION INTO THE LAMP EFFICIENCY

In the past century different technologies have been used to generate light. Nowadays insect traps are commonly executed with the fluorescent lamps, used to generate the much desired UV-A light. But a new technology is gaining ground fast.

A quick run-down on the various technologies used to create light:

- A. Incandescent light bulbs were used for over 100 years to generate light. Due to its low efficiency (a typical 5% efficiency was found in these lamps) this technology was banned out.
- B. Fluorescent lamps have a higher energy to light conversion and can offer up to 33% efficiency. However: This efficiency level is only achieved by lamp producers who control every aspect of the lamp production process and only for those lamp types which have the lamp process conditions to reach this efficiency level. (like the 15 watt lamp ranges, produced by Philips)

Details on the current range of our fluorescent lamps can be found on page 18

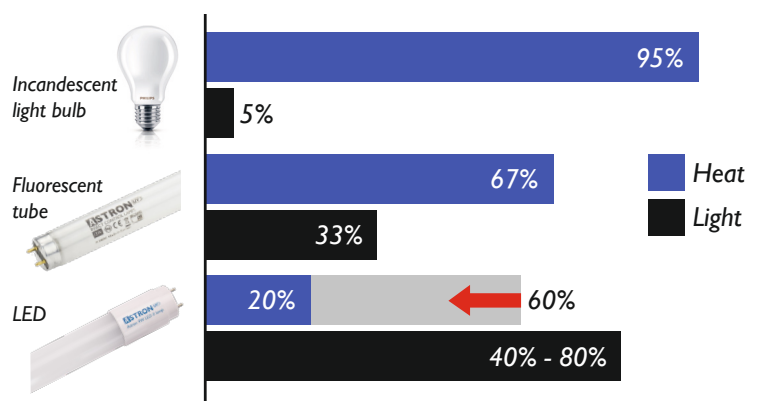

14

The efficiency of light production varies by type of lamp(bulbs) employed

- C. In the past decades a new technology has entered the market; LED technology. This technology can offer a energy to light conversion of as high as 80%. For the UV-A LED it may take some time before we reach this efficiency level, but current UV-A LED technology has already proven to be more efficient than fluorescent lamps. And this technology will continue to improve its energy to light efficiency ratio over time

UV-A LAMP TECHNOLOGY - LAMP COATING TECHNOLOGY

Lamps used in areas where food consumption, food production or preparation takes place need to be executed in such a way that consequences from a possible glass breakage are safely addressed.

Glass fragment may never enter into food products. The same standard is commonly used in industries, who also consider glass

breakage as an unacceptable risk factor: pharmaceuticals, cosmetics and many other industries.

For this reason the UV-A lamps are executed with a special sleeve, which is produced from UV-A transparent material: the so-called shatterproof coating.

The shatterproof material used is very strong, durable and has a high UV-A transparency rate. It can fulfil the related national standard BS 6062 and DIN 52290:

- 1) 30.000 hours lifetime.
- 2) Ensures that at a lamp drop from 5 meters, the glass fragments will be retained in the sleeve.
- 3) More than 95% transparent for UV-A light.
- 4) Melting point over 280 Celsius degree.

GLUEBOARDS

The adhesives used for the boards are glues with very special characteristics designed to grab and then hold very light but often strong insects over an extended period of time under very demanding conditions.

Insects are extremely light and create little or no pressure on the areas where they land. If the designated landing area is a glueboard, then we still want these insects retained on the board with no change of escaping. In addition to this demand we want the boards to be handled easy and at a wide variety of temperatures.

From close to 0° C up to 65° C, the glueboards will have to perform its function: keep the insects on the board.

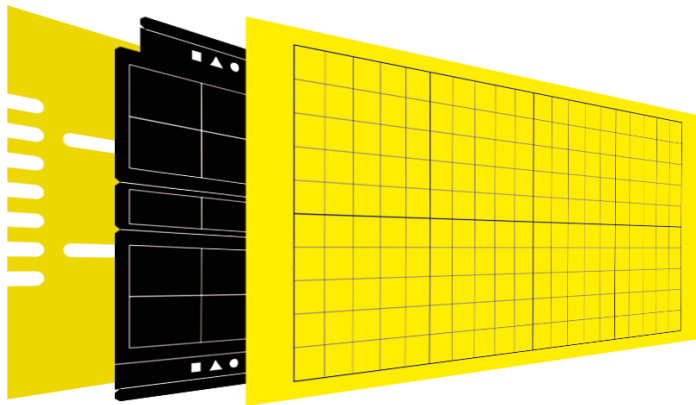

Not only the glue needs to be of excellent quality, but also the actual board must be optimised for this task. It needs to be strong enough and may not deform over time.

What does Alcochem

Water protected varnish on all sides of the board

Grid structure allows fast (digital) monitoring

Powerfull UV-A resistant, non-dripping glue

Our yellow and white boards offers (by digital

counting) discretion and fast monitoring

A full range of boards, suited for a wide variety of insect control units.

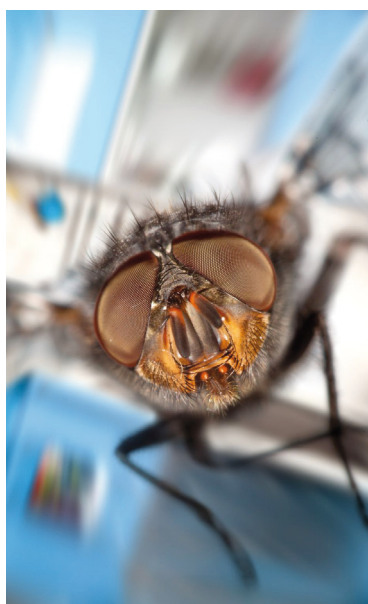

Specifications

Glue type	:	UV-A stable glue
Storage temperature	:	0 - 40 degrees Celsius
Storage time	:	Max. 18 months under dry conditions
Field temperature	:	0 - 60 degrees Celsius
Packing	:	Packed per 10 pieces in a set
Bulk packing	:	Packed per 10 sets/export box
Material	:	Plastic, paper or Corex
Glue sides	:	Glue on 1 side (S = Single) or 2 sides (D = Double)
Color paper boards	:	executable up to full color
Color plastic boards	:	executable with one color
Corex boards	:	not printable
Production	:	Acc. ISO 9000 standards

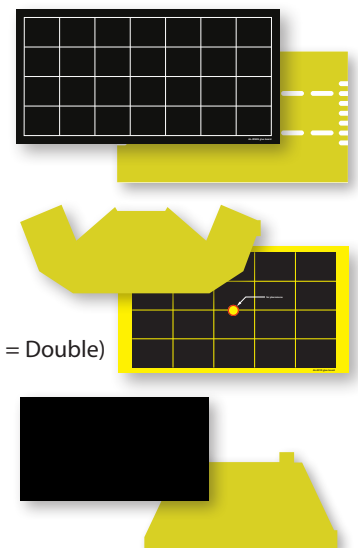

BLUETOOTH UV-A TESTER



Analysing UV-A lamps with your Smartphone It's a tiny, beautifully designed with Aluminum body, UV tester that connects to your phone to measure and analyse the UV-A light from UV lamps. Prior to taking a UV-A reading, make sure that the lamp has been working for at least 5 minutes.

Depending on the ambient temperature, it can take up a few minutes for a UV-A lamp to reach its full UV-A output.

- Model : UV-A lamp tester BT
- Suitable for : Measuring UV-A lamps (lamp types as shown in the App)
- Interface : Bluetooth 4.2 BLE (Bluetooth Low Energy)
- UV-A : measuring range 310-400 nm
- Accuracy : +/- 20 %
- Battery : CR2032 Button cell
- Size : 40 x 80 x 17 mm
- Weight (incl. bumper): 38 gram
- Smartphones : operating Android 4.2 or higher, iOS 8.0 or higher
- Supported Bluetooth : 4.0 or higher
- Material bumper : Silicone
- Approval : CE approved
- Protection level : IP20



UNIMAR®

Website : www.unimarcorp.com



Dubai - UAE Head Office

Tel: +971 4 3244332

Abu Dhabi - UAE

Tel: +971 2 5503232

Sharjah - UAE

Tel: +971 6 5341533



Hazmieh - Lebanon

Tel: +961 5 459011



New Jersey - USA

Research & Development